



Maximising SAN Resource Utilisation

徐博
网域存储技术有限公司
<http://www-cn.netapp.com>

- ▶ **Introduction**
- ▶ **LAN Free Backups**
- ▶ **High Availability and Disaster Recovery**
- ▶ **Improving Capacity Utilisation**

- ▶ **Introduction**
- ▶ LAN Free Backups
- ▶ High Availability and Disaster Recovery
- ▶ Improving Capacity Utilisation



Network Appliance brings
unmatched simplicity
to the complex world of
enterprise data management.

- ▶ **Reduce cost & complexity**
- ▶ **Minimize risk**
- ▶ **Control change**

Delivering Customer Satisfaction

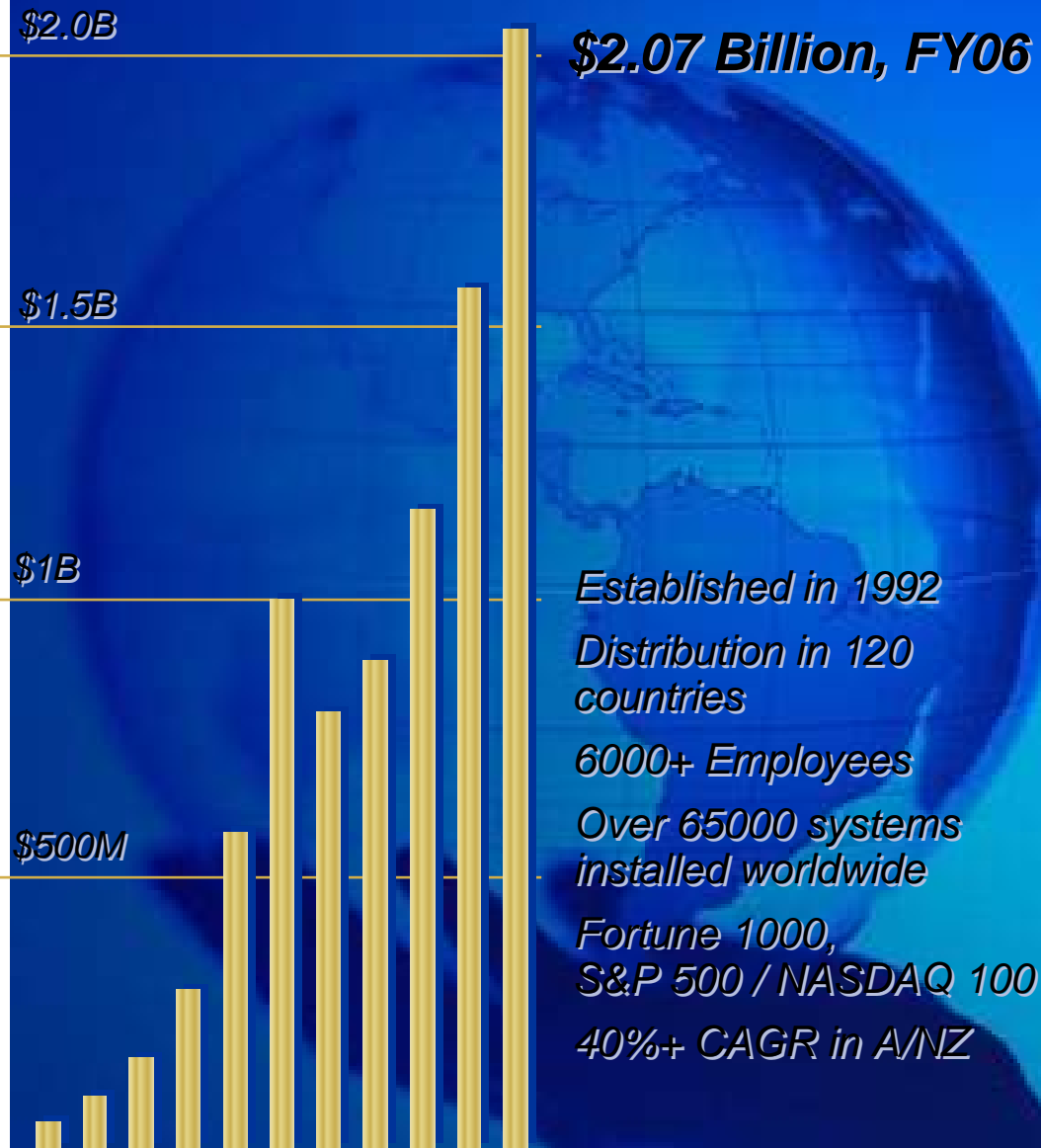

- ▶ **Fastest** growing storage business
- ▶ **Comprehensive** data management solutions portfolio
- ▶ **World-class** service & support
- ▶ **Global enterprise** customer base
- ▶ **Delivers** more TB than **EMC** (IDC measurements)



Gartner Midrange Enterprise Disk Array Magic Quadrant – 2006 vs 2005

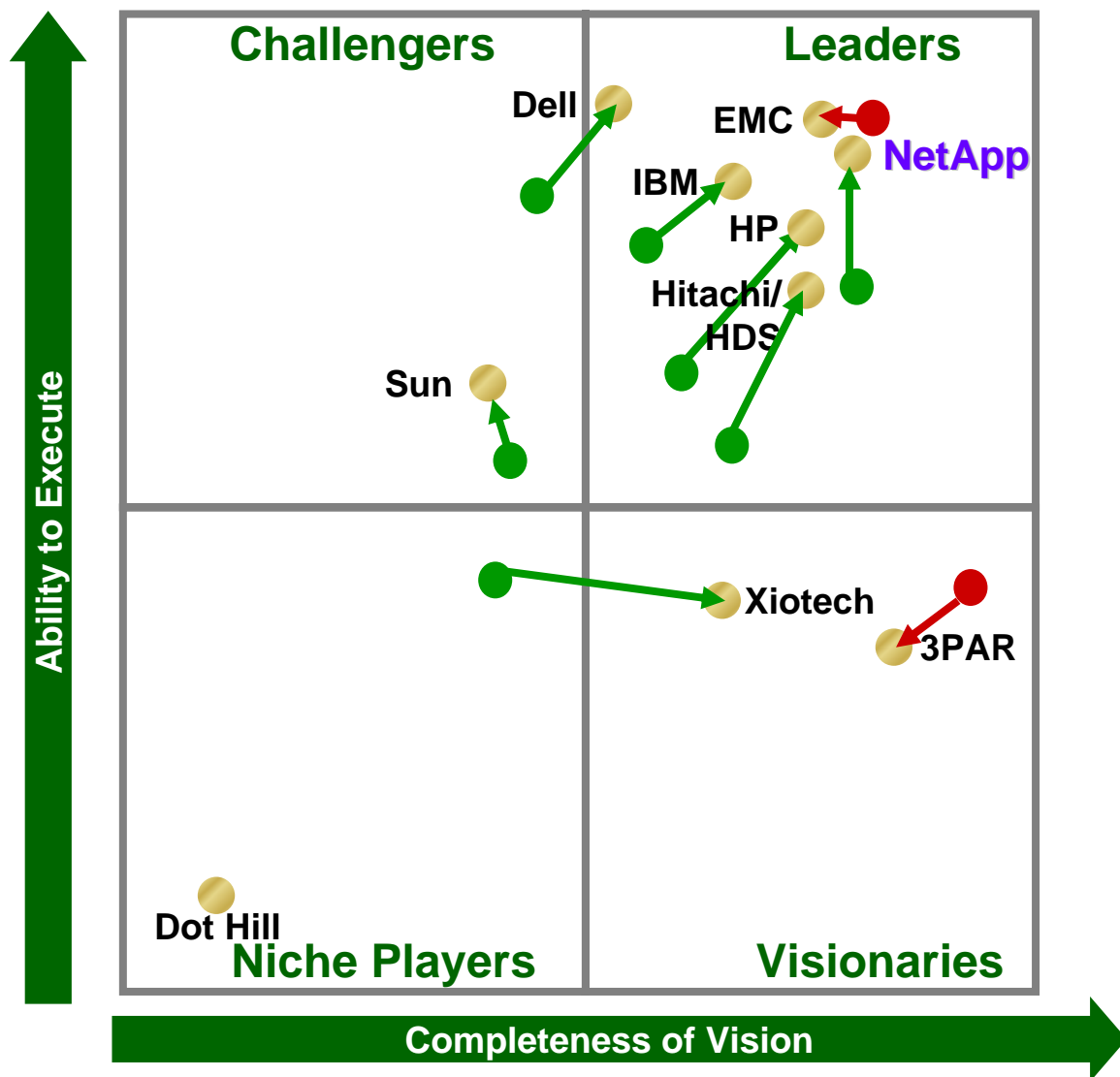

New Additions to the 2006 Magic Quadrant

Challengers:

- NCR
- Fujitsu

Visionaries:

- Pillar
- EqualLogic
- Compellent
- BlueArc

Niche Players:

- Nexsan
- SGI
- DataDirect
- Intransa

Source: Gartner, Inc., Dec 2006
Magic Quadrant for Midrange Enterprise Disk Arrays, 2H06

- ▶ Introduction
- ▶ **LAN Free Backups**
- ▶ High Availability and Disaster Recovery
- ▶ Improving Capacity Utilisation

The problem with LAN Backups

Where bottlenecks appear

- Clients
- Network
- Backup server
- Tape Drives / Media

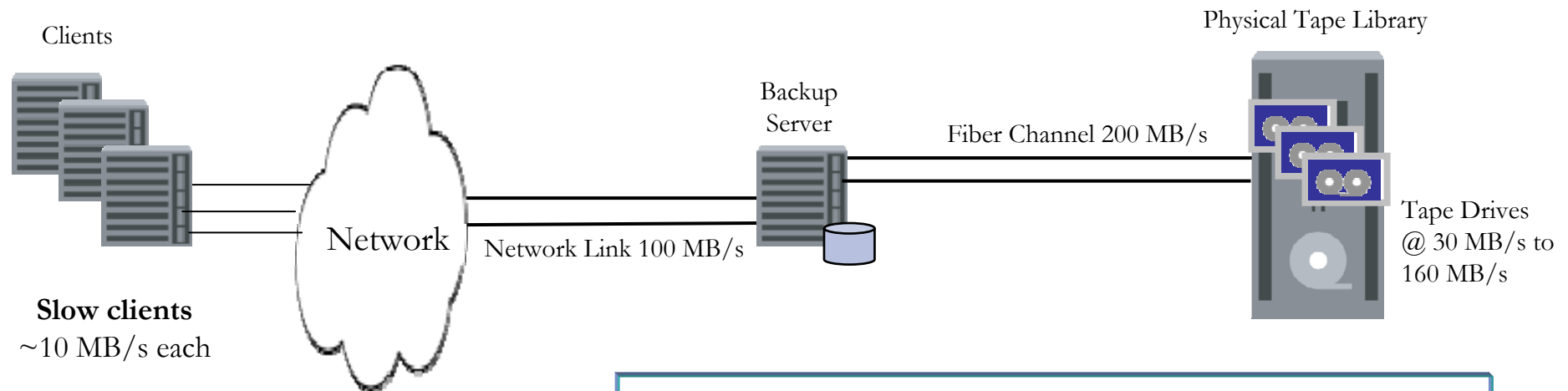

A typical scenario

- Storage grows faster than infrastructure can support
- Backup schedules are staggered to avoid contention
- Client and tape drive speeds remain mismatched
- Backup and recovery service levels continue to deteriorate

▶ **Benefits**

- Reduced load on LAN
- Improved speeds for some backups

▶ **Challenges**

- Tape Drives were never designed to be shared
- Difficulty in keeping tape drives streaming
- Multiplexing can't be used effectively
- Tape

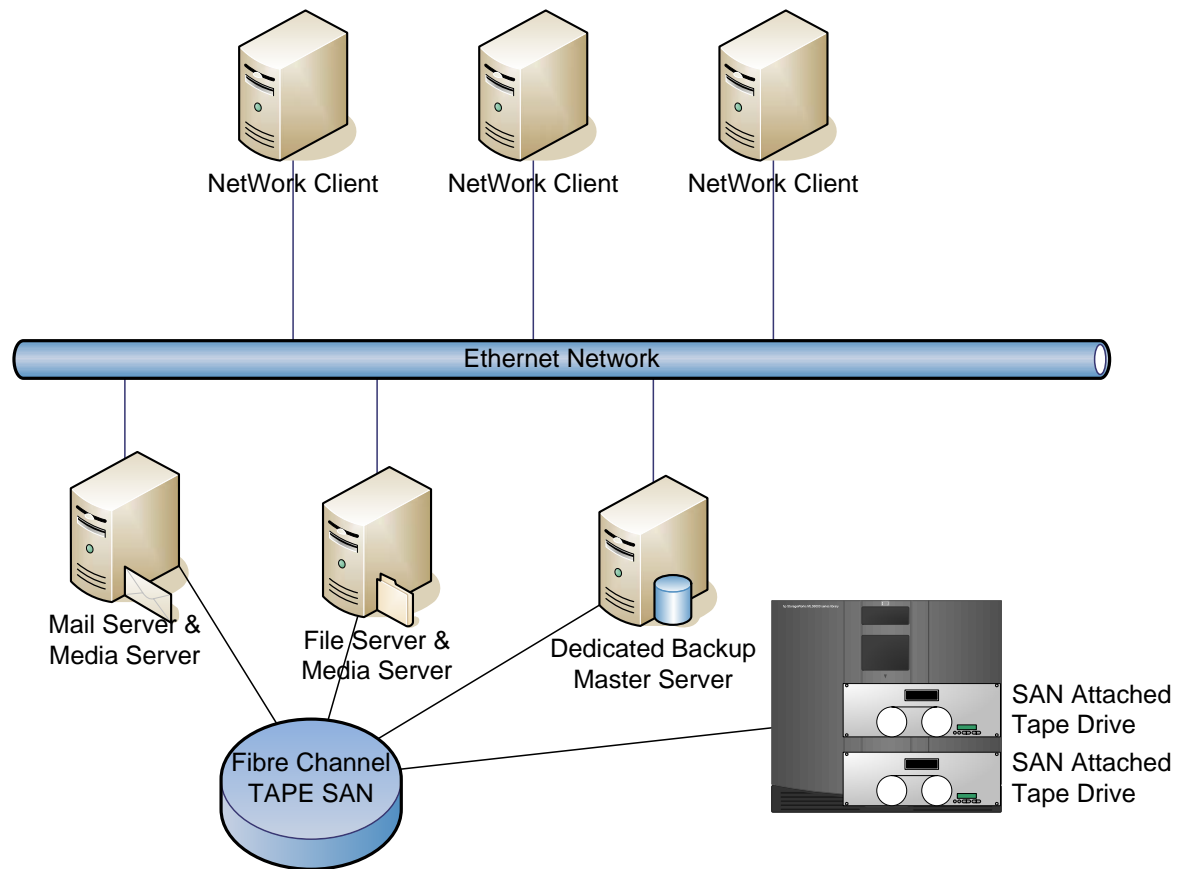

The problem is not the SAN

Common Obstacle to Achieving Maximum Backup Performance

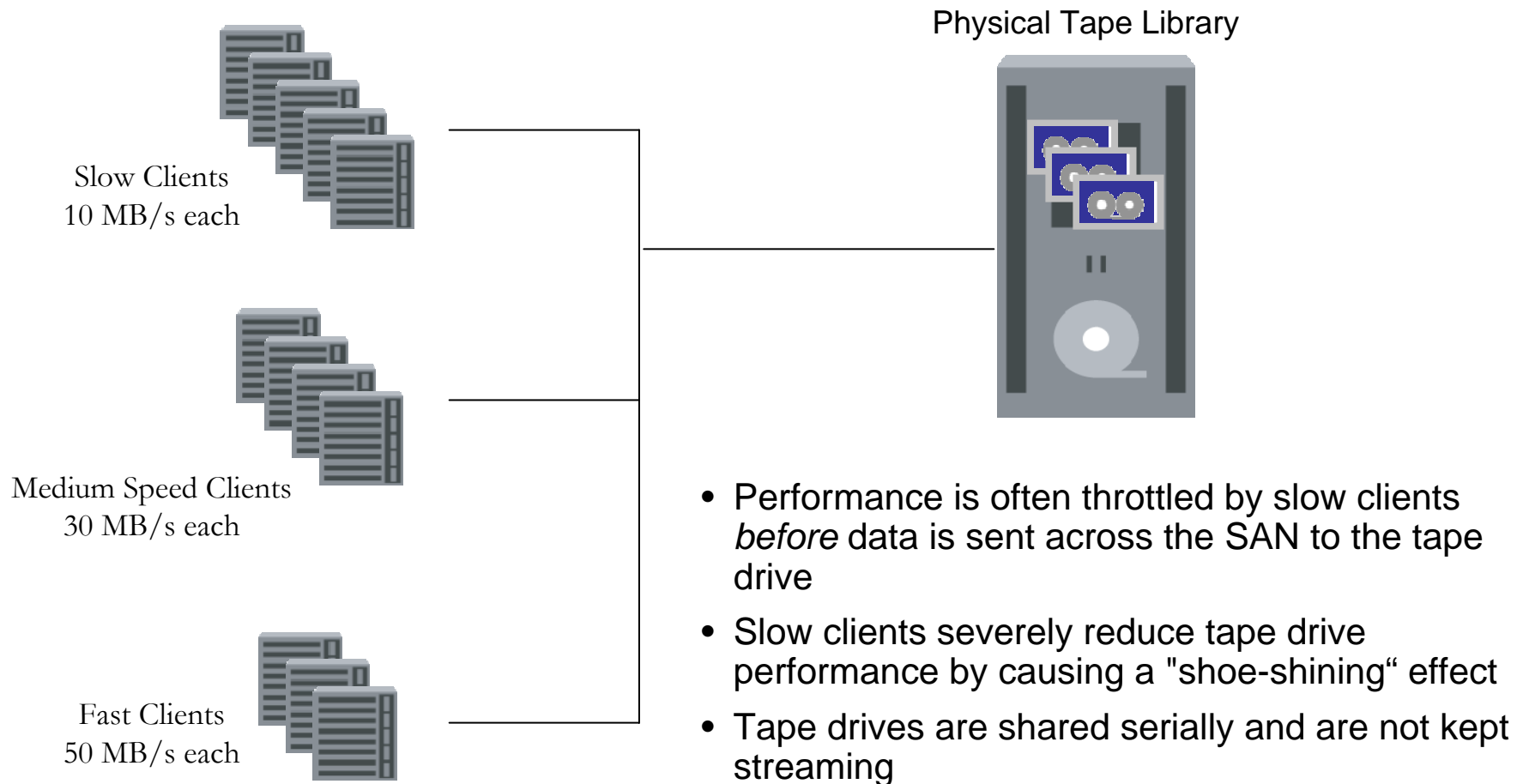



Optimizing the SAN backup infrastructure

What VTLs provide

*Every server gets its own tape drive that does not suffer from back-hitch.
Virtual tapes are copied to physical tape as a high speed post process
100 % Compatible with All backup product media management practices*

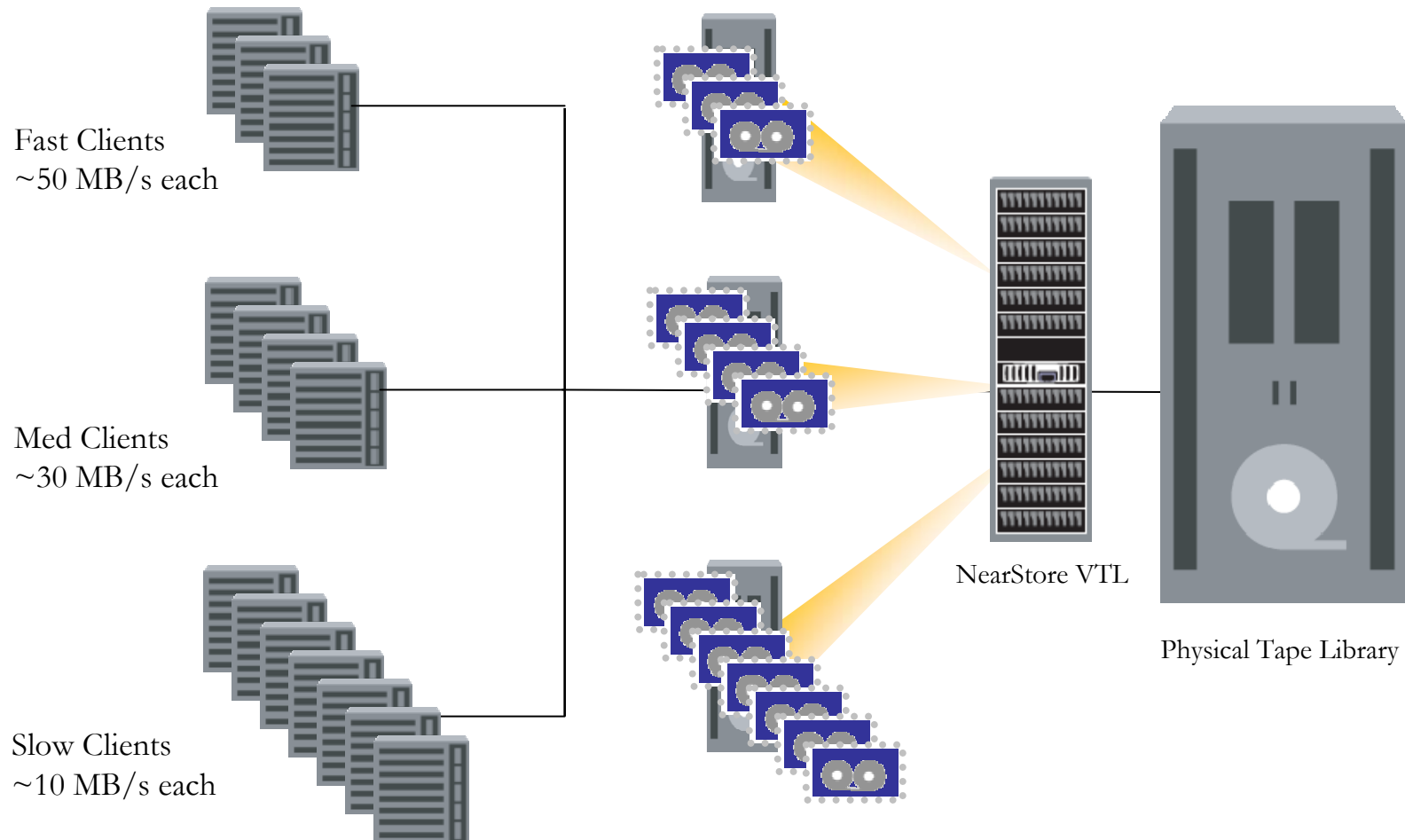

- ▶ **Self-tuning Performance**
 - Automatically optimizes performance
 - No manual tuning is required
- ▶ **Direct Tape Creation**
 - Out-of-band 100% native format physical tape creation
 - Fast and flexible restore options
- ▶ **Tape Smart Sizing**
 - 50% savings in physical tape vs. other VTLs
- ▶ **NetApp Technology Ownership**
 - Simplicity, support and enhancements



The Requirement for Self Tuning VTLs

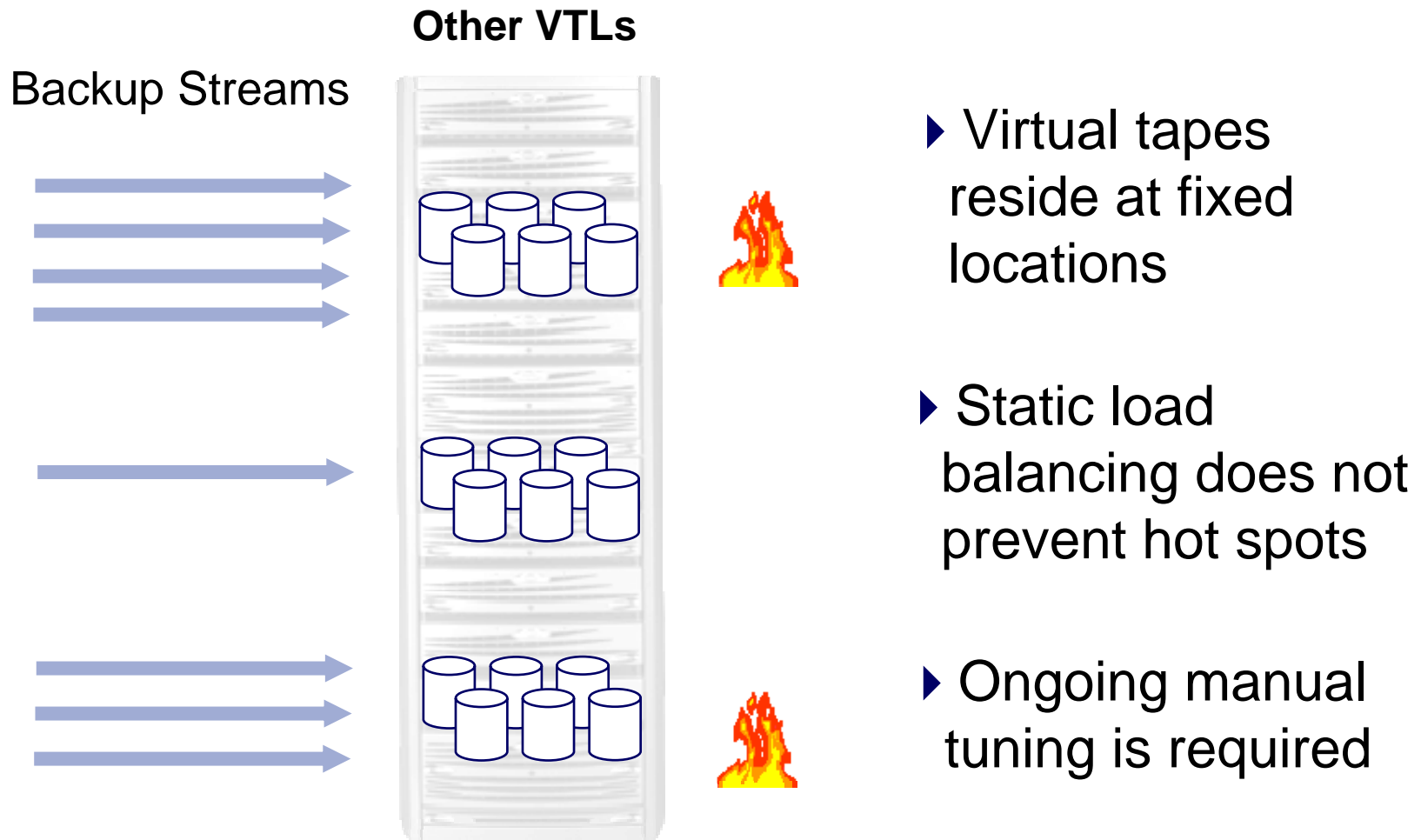

Dynamically Balanced
Backup Streams

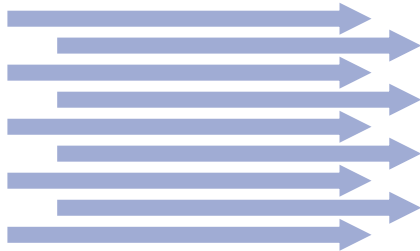

NearStore VTL

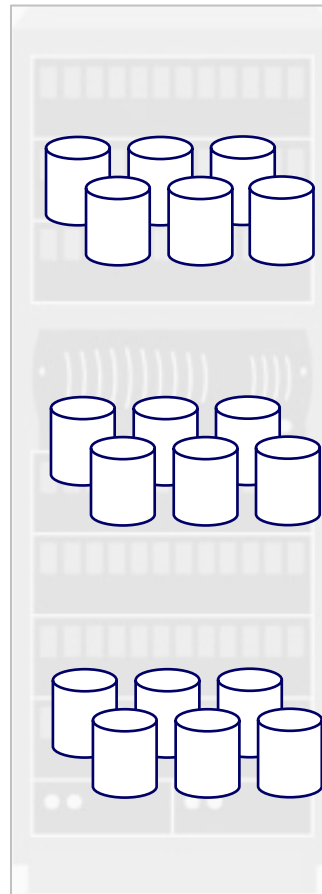

- ▶ Virtual tapes do not reside at fixed locations
- ▶ Backup streams are dynamically load balanced across disk LUNs
- ▶ Provides optimal performance without tuning

Dynamically Balanced
Backup Streams

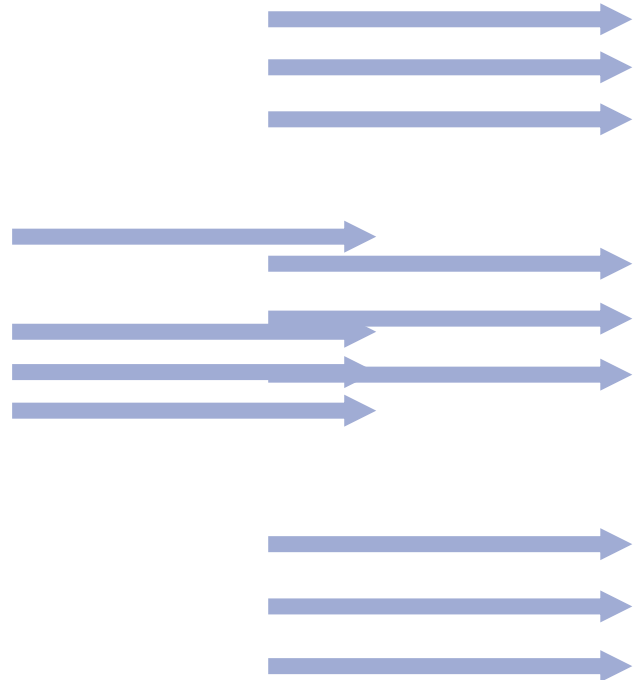

NearStore VTL

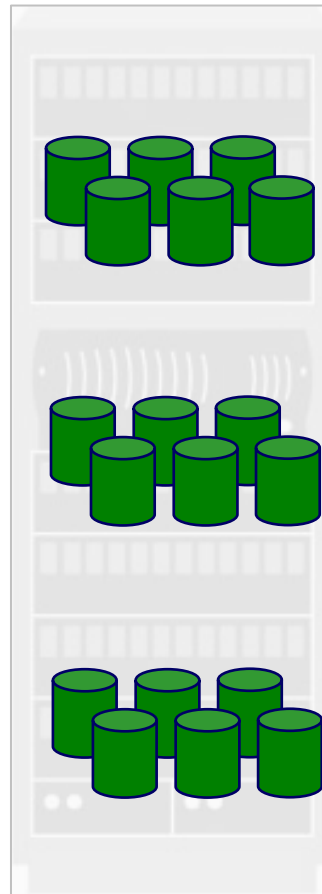

- ▶ Backup streams are automatically re-balanced as the backup load changes



NearStore VTL Self-tuning

Third-party test findings

Multiple Backups at Varying Rates - 20 Streams

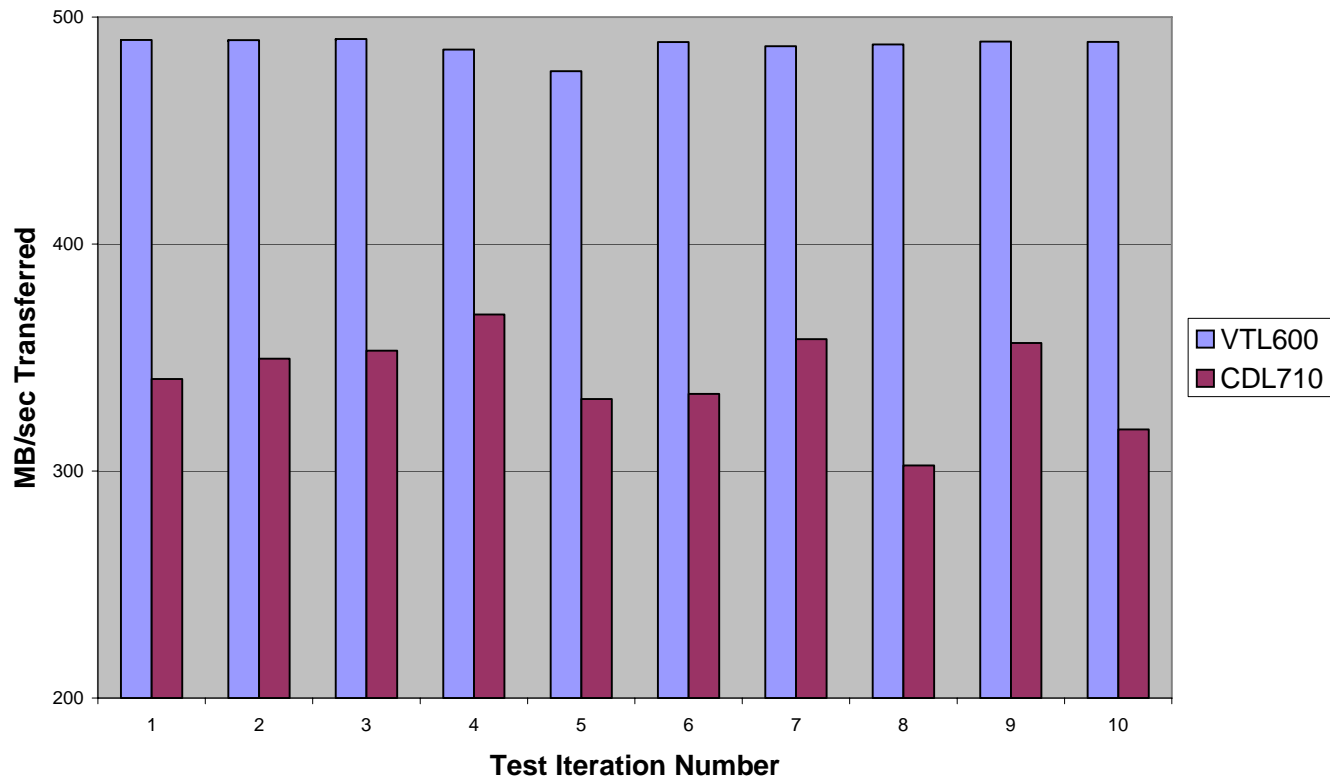

NearStore VTL performed 33% to 57% faster than a leading competitor in ten separate tests with mixed speed backups

Source: Veritest Performance Comparison, July 2006

- ▶ Introduction
- ▶ LAN Free Backups
- ▶ **High Availability and Disaster Recovery**
- ▶ Improving Capacity Utilisation



NetApp's Data Protection Solutions

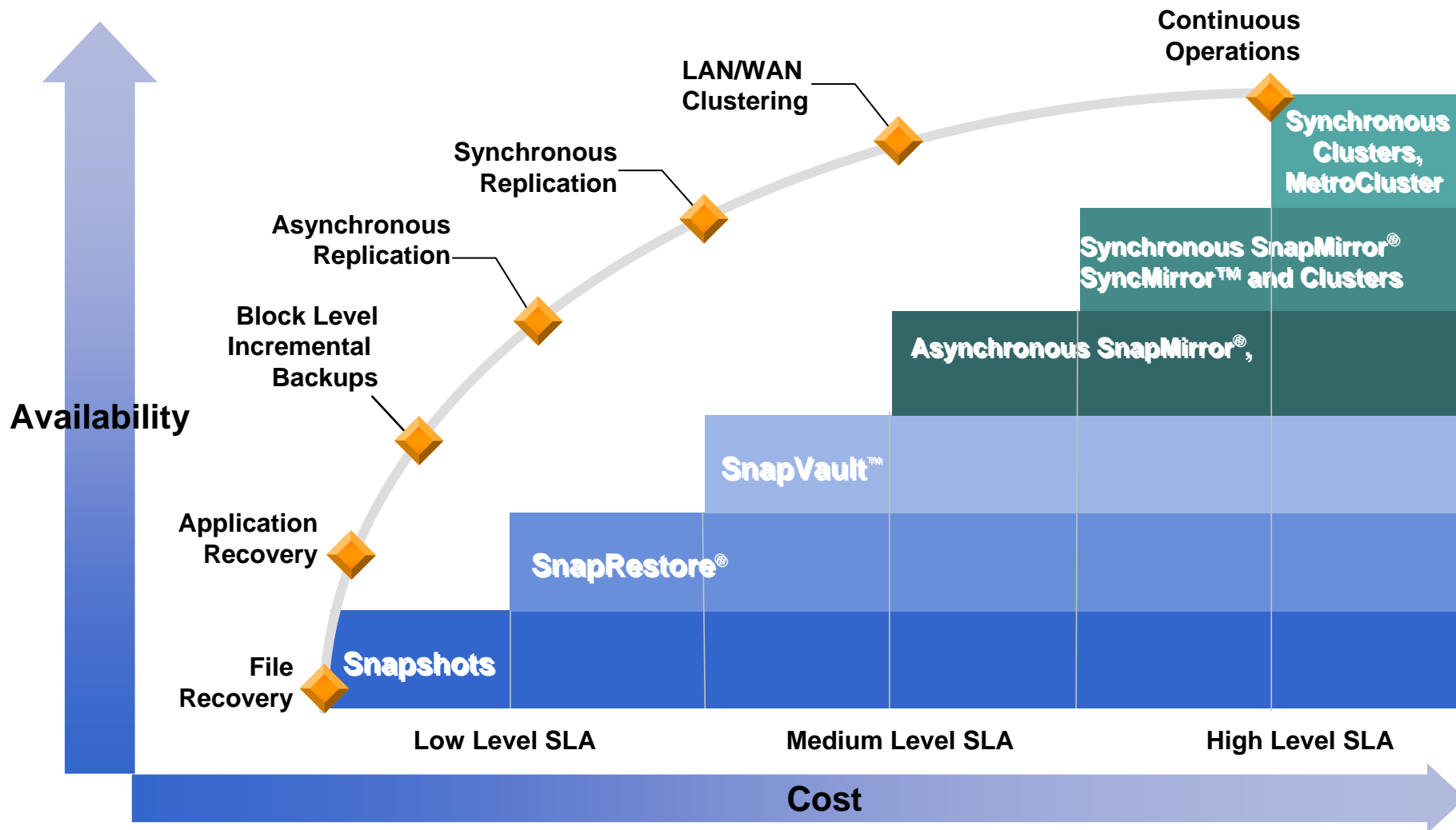

▶ Benefits

- Broad Cluster and Application Support
- Synchronous over 100KM+
- Lower latencies compared to IP

▶ Challenges

- Double the number of storage controllers
- Performance Impact on storage controllers
- Extra spindles purchased do not add to performance
- Additional latency may slow down production application

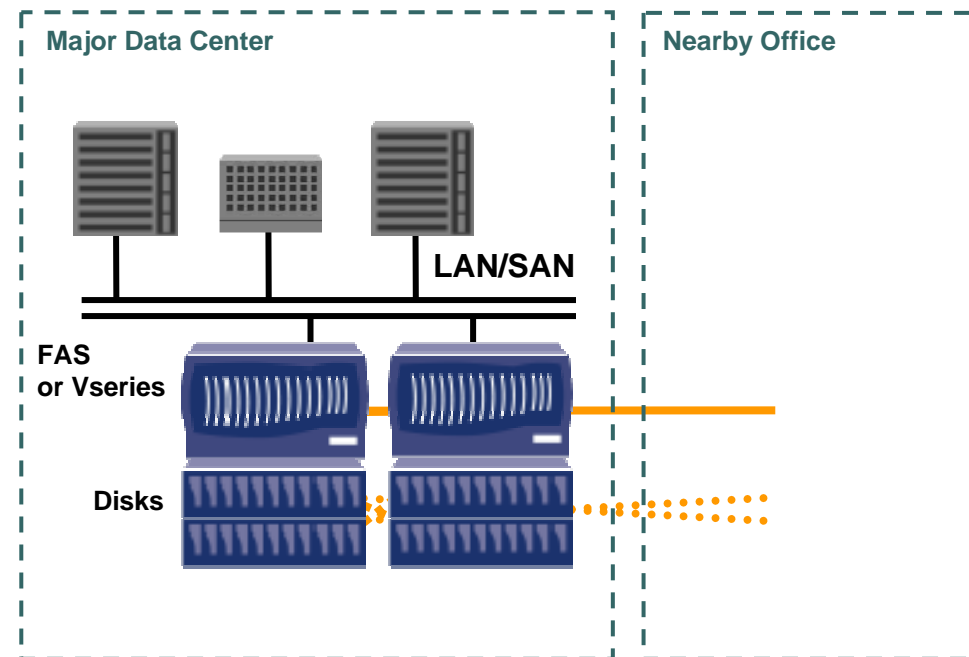

Stretch MetroCluster – Campus distances

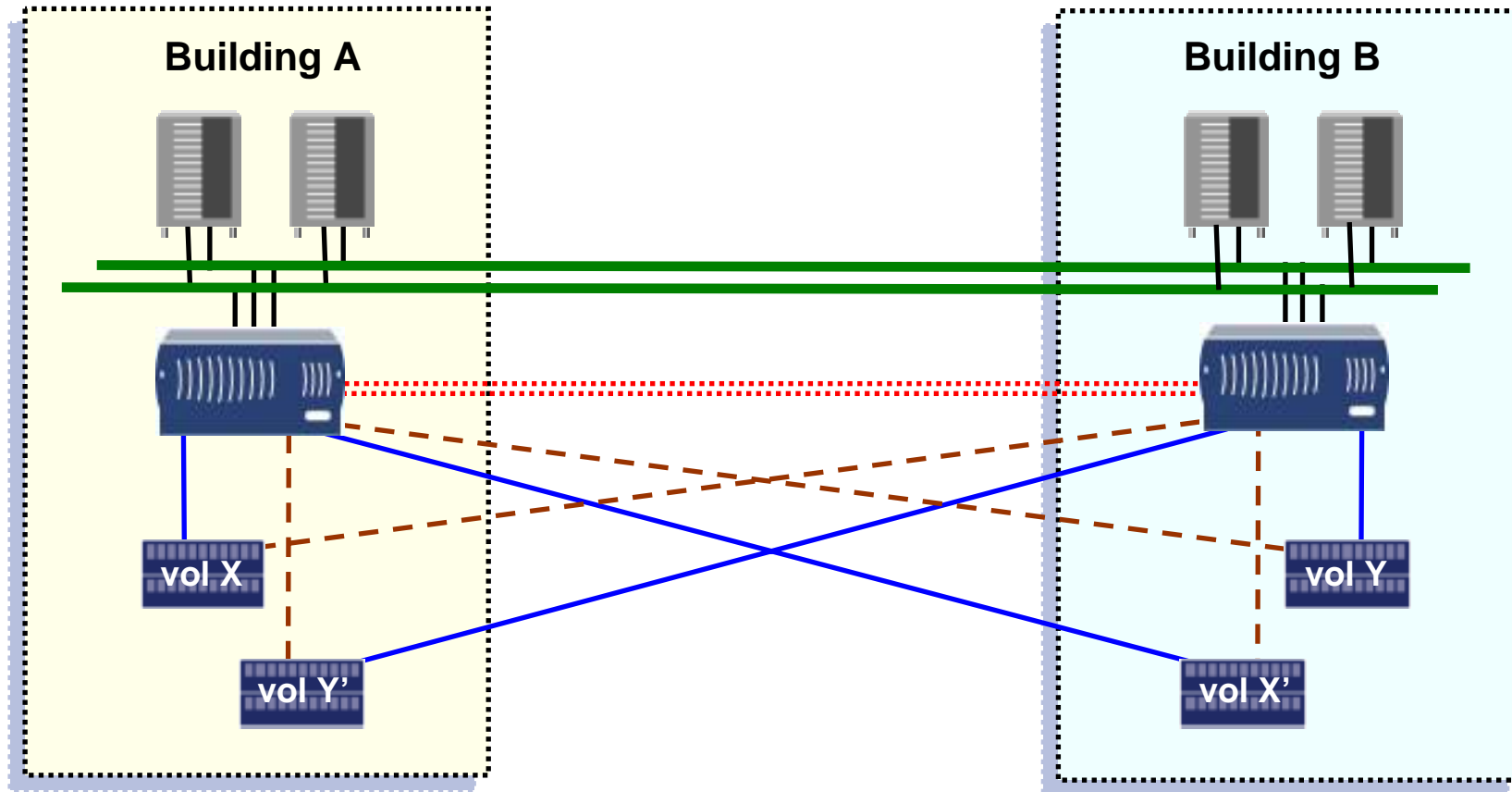

- Storage Controller interconnect
- A-loop
- - - B-loop

Similar to local high availability configuration, but with long cables

Fabric MetroCluster

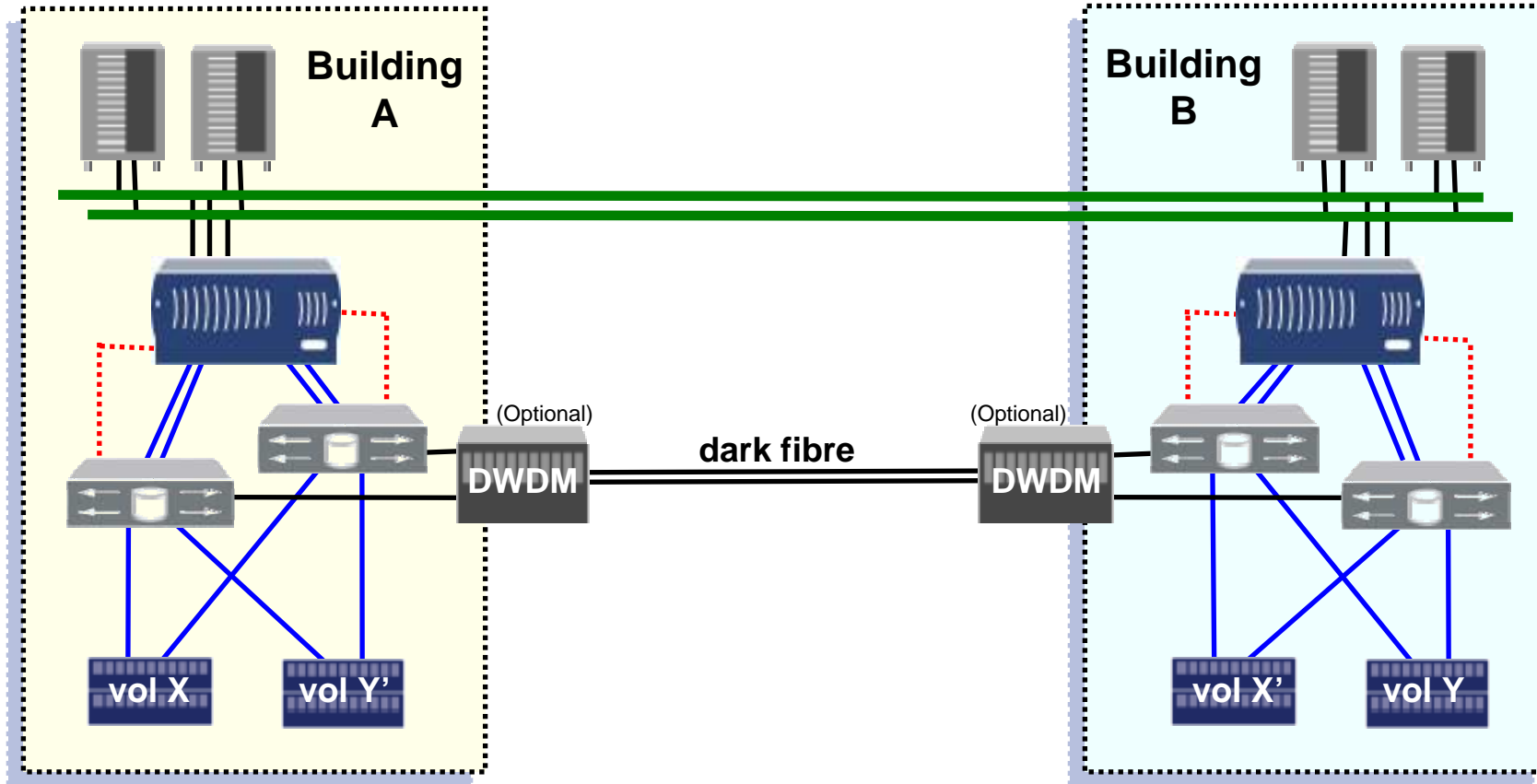

..... Cluster interconnect

No SPOFs – redundancy in all components and connectivity
All Brocade Switches and DWDM Solutions supported

MetroCluster – Disk Failure

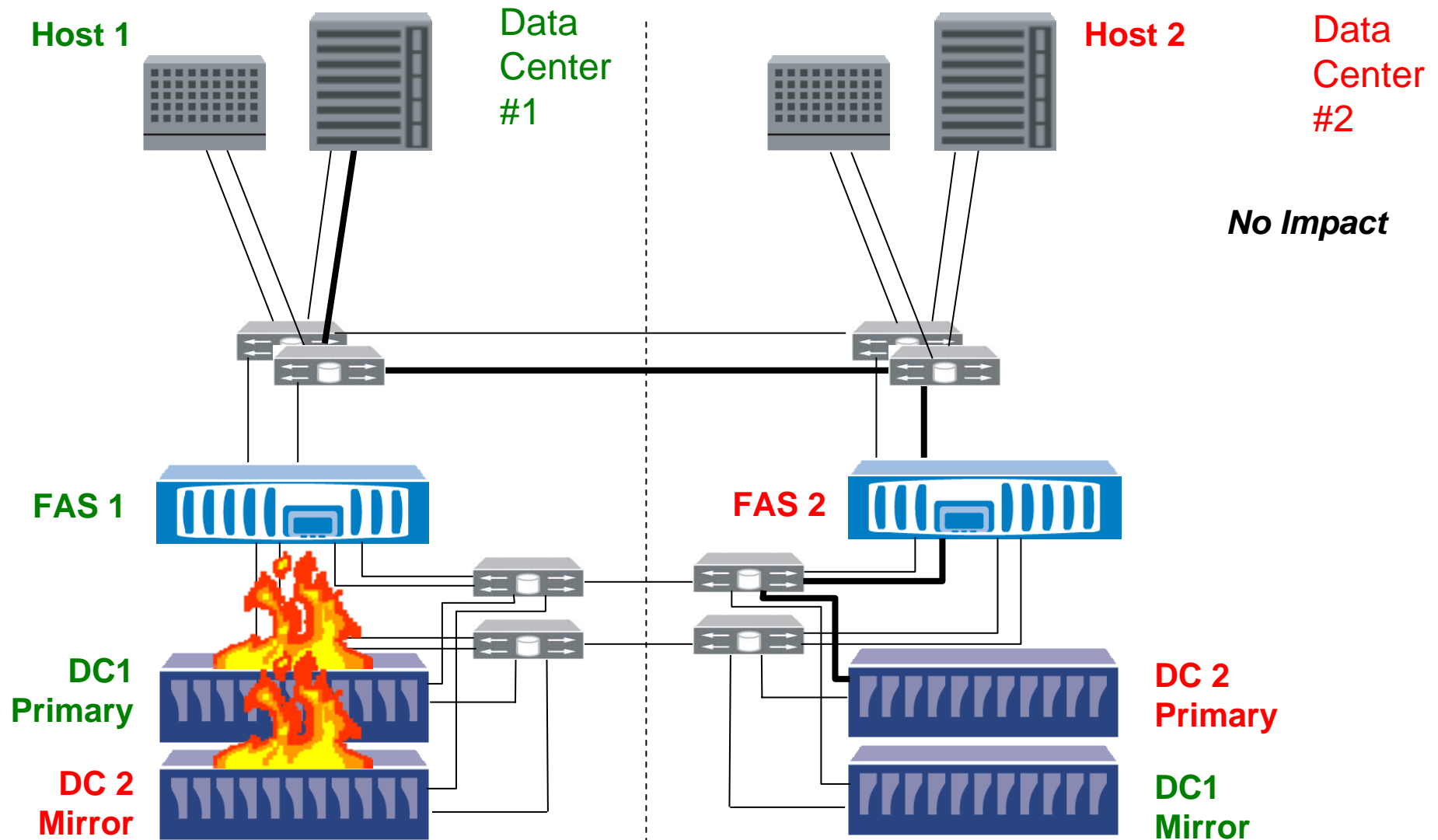

MetroCluster – Controller Failure

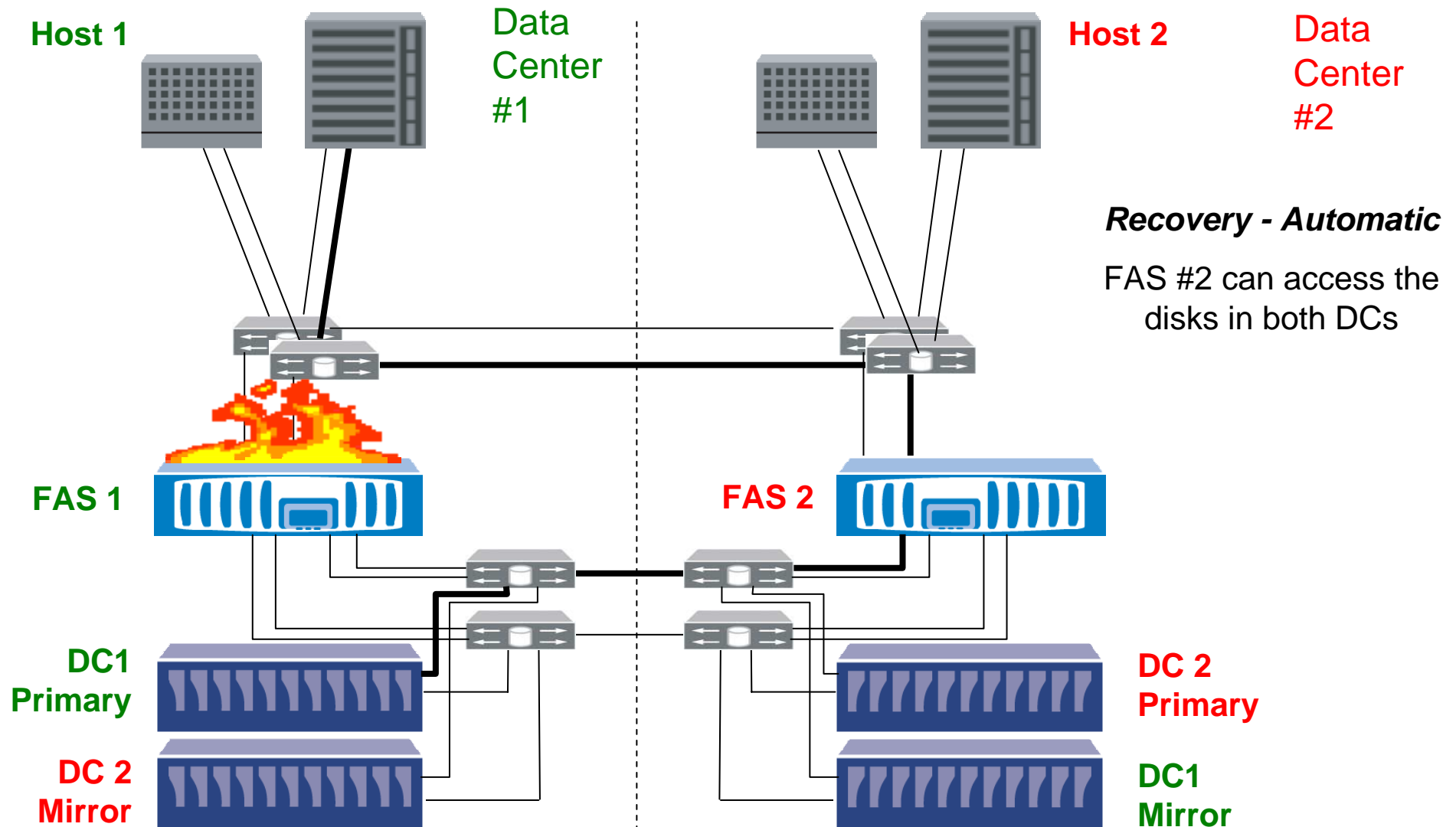

MetroCluster – Interconnect failure

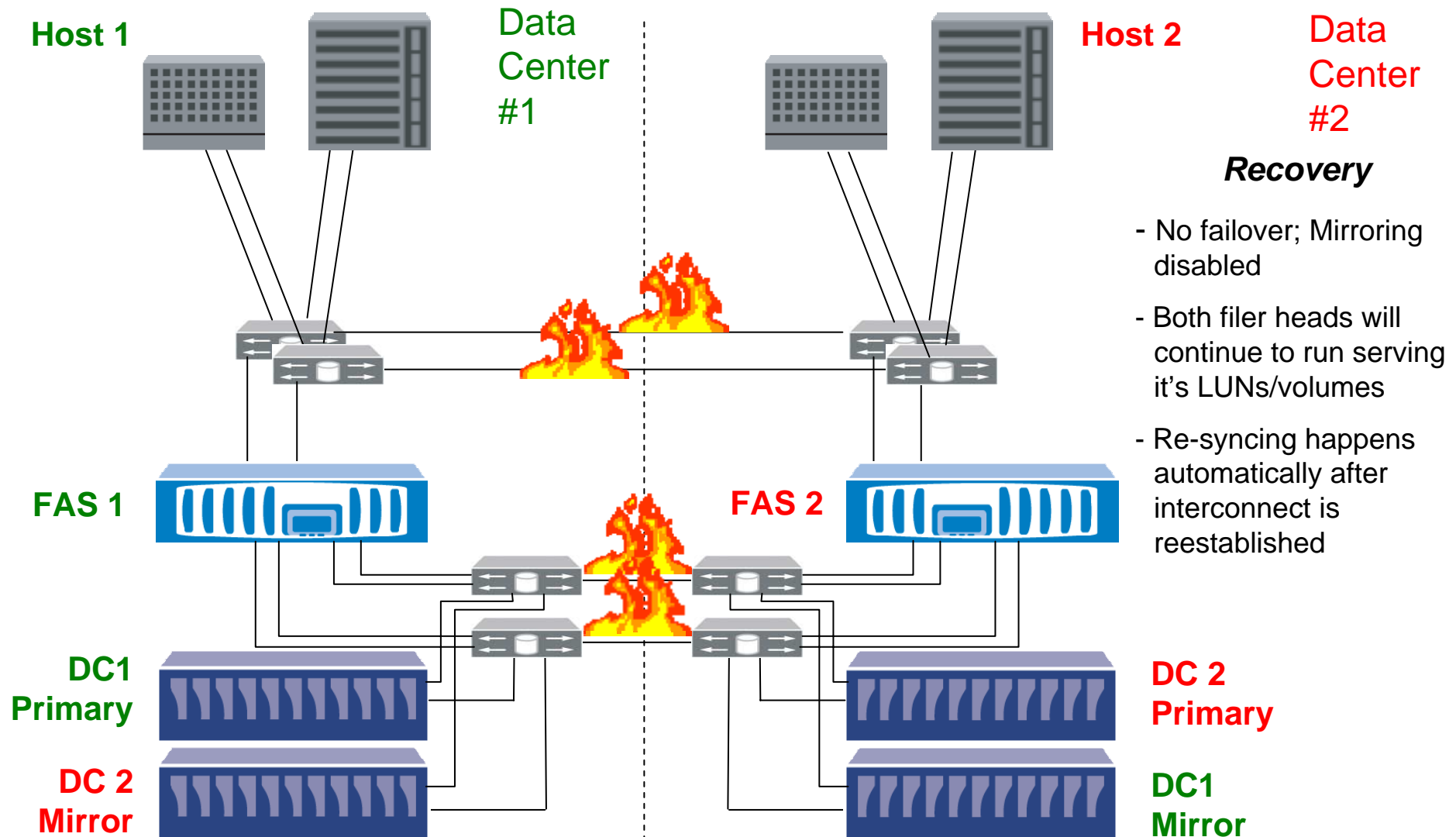

Recovery

- No failover; Mirroring disabled
- Both filer heads will continue to run serving it's LUNs/volumes
- Re-syncing happens automatically after interconnect is reestablished

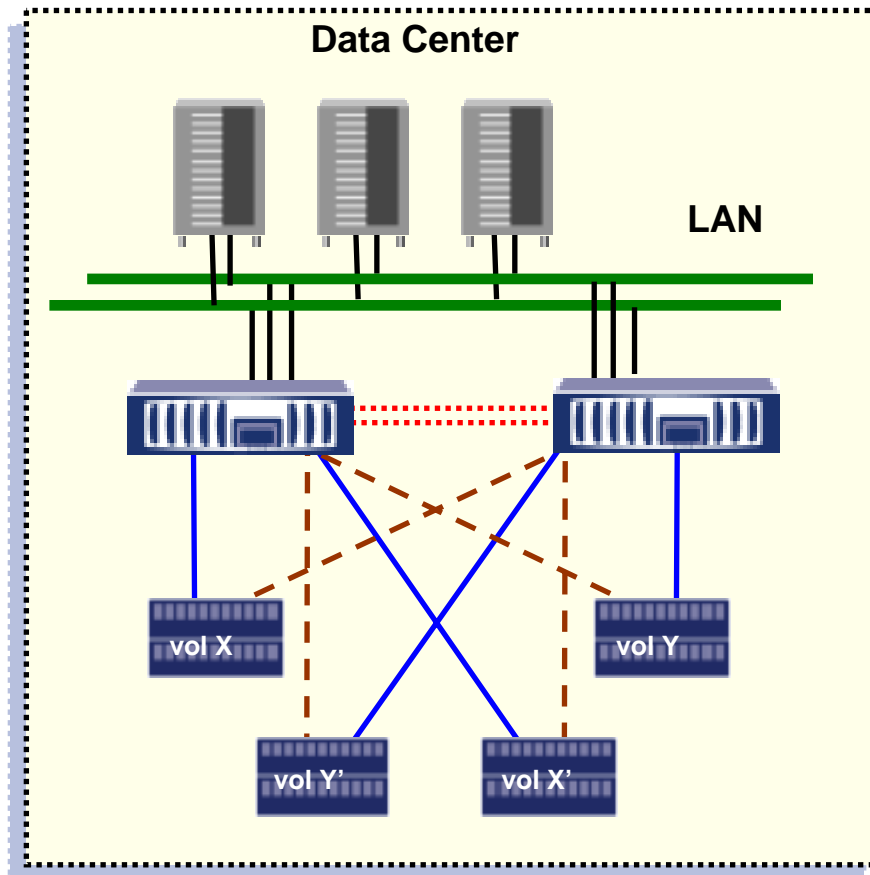

- ▶ **Synchronous Fibre Based Replication using SAN infrastructure**
- ▶ **Half the number of storage controllers compared to other mid-range platforms**
- ▶ **Increases Read Performance**
- ▶ **Resilient to 4 disk failures within a single RAID group**
- ▶ **Can be combined with all other NetApp data protection solutions**

- ▶ Introduction
- ▶ LAN Free Backups
- ▶ High Availability and Disaster Recovery
- ▶ **Improving Capacity Utilisation**

- ▶ **Increase storage utilization by lowering allocation for headroom - unused storage that will be used within one to two years**
- ▶ **Decrease storage capital expenditures by enabling the purchase of storage on an "as-needed" basis**
- ▶ **Increase administrative staff productivity - manage more storage with fewer personnel**
- ▶ **Reduce application downtime and minimize business impact for storage upgrades**
- ▶ **Create a centralized network environment for storage and server platforms**

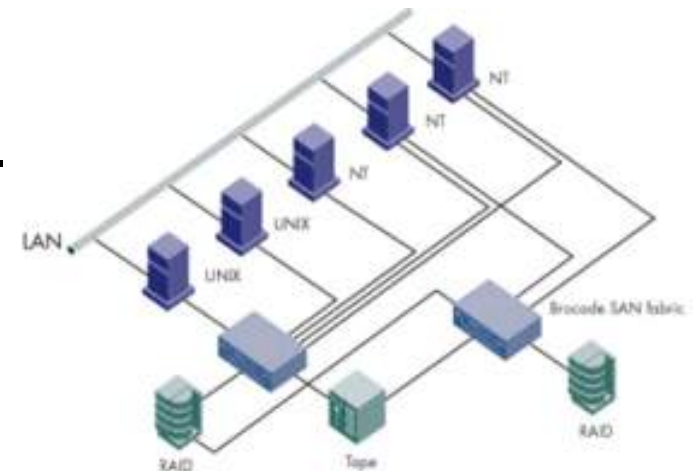



- ▶ **John Toigo: Companies .. are finding that they're using less than 40% of the capacity of the array ..**

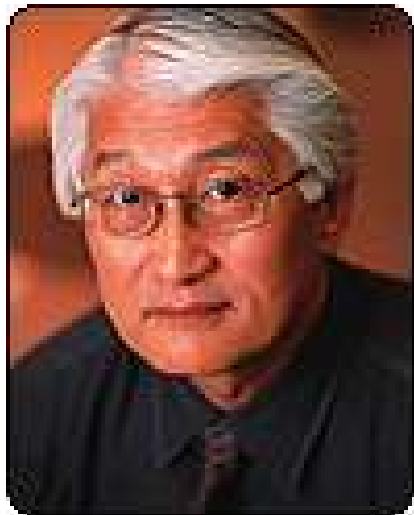

- ▶ **Hu Yoshida: The growth rates for external disk storage have increased to about 60% over the last two years, while utilization of storage has been dropping to about 30%**
- ▶ **... The CIO of a large financial company .. said that his storage was only 20% utilized, and over 70% of it was expensive tier 1 storage**



- ▶ **“Experts recommend provisioning LUNs at least 30% to 50% larger than the expected size.**
- ▶ **Ideally, administrators want to size the LUN on the basis of performance requirements, efficient capacity utilization or protection**

▶ http://whatis.techtarget.com/originalContent/0,289142,sid5_gci1226560,00.html

- ▶ **Thin Provisioning**
 - Gives end users what they need instead of what they think they need
 - Works particularly well for filesystem environments
 - Requires careful monitoring
 - Makes DBA's very nervous

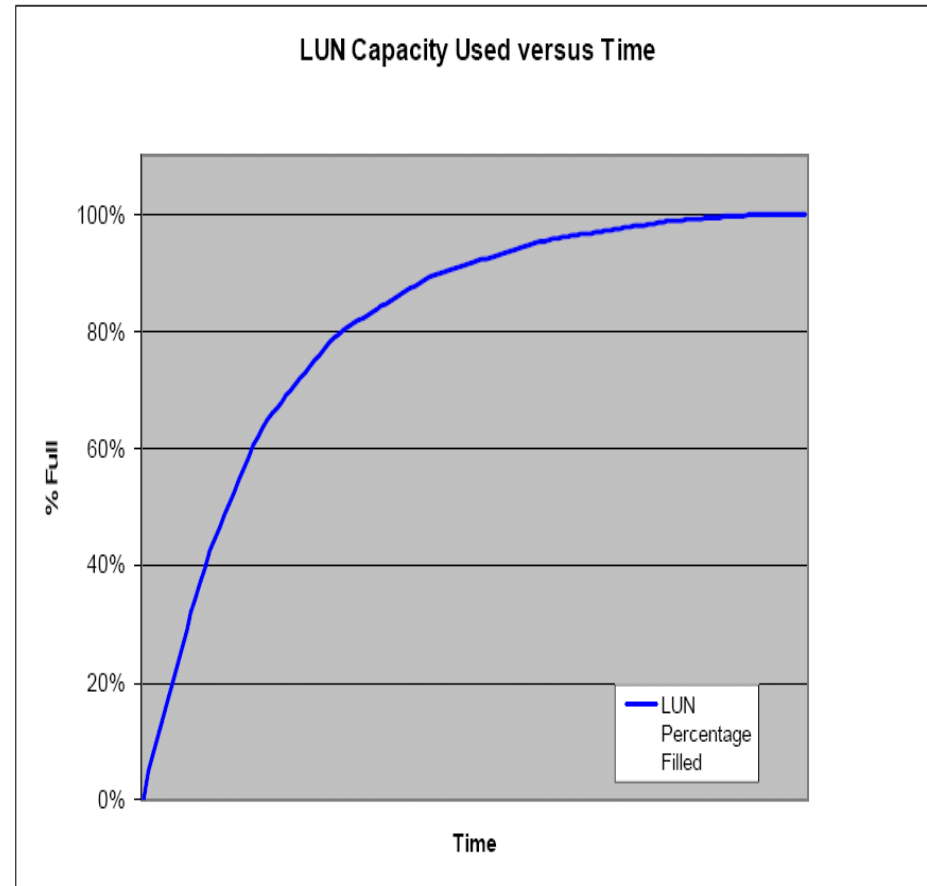

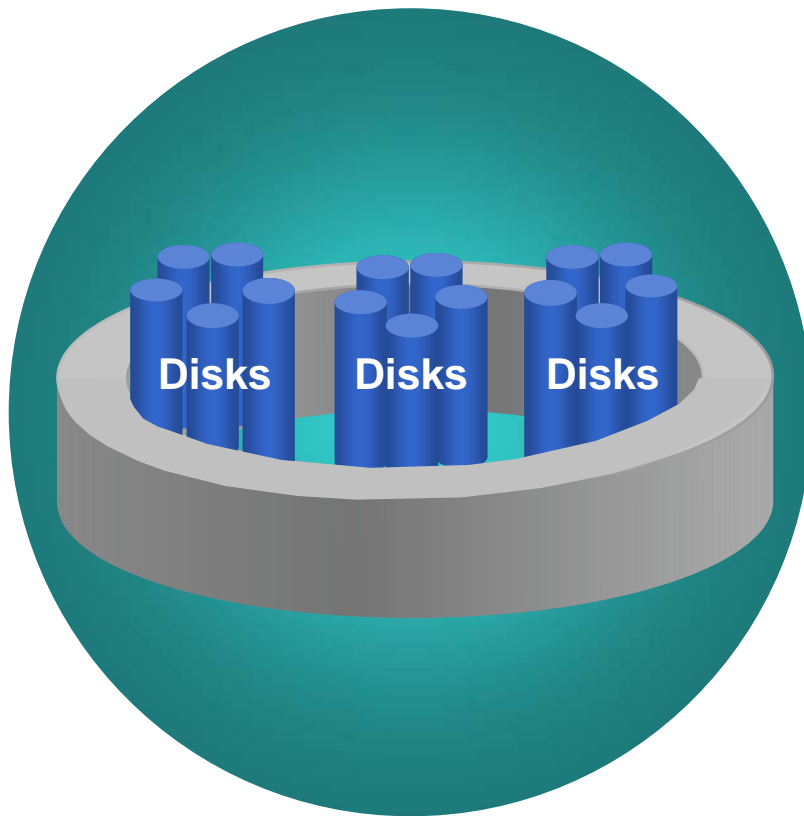

- **First Create a Storage Aggregate from your pool of disks**
- **This is both a capacity and performance aggregate**

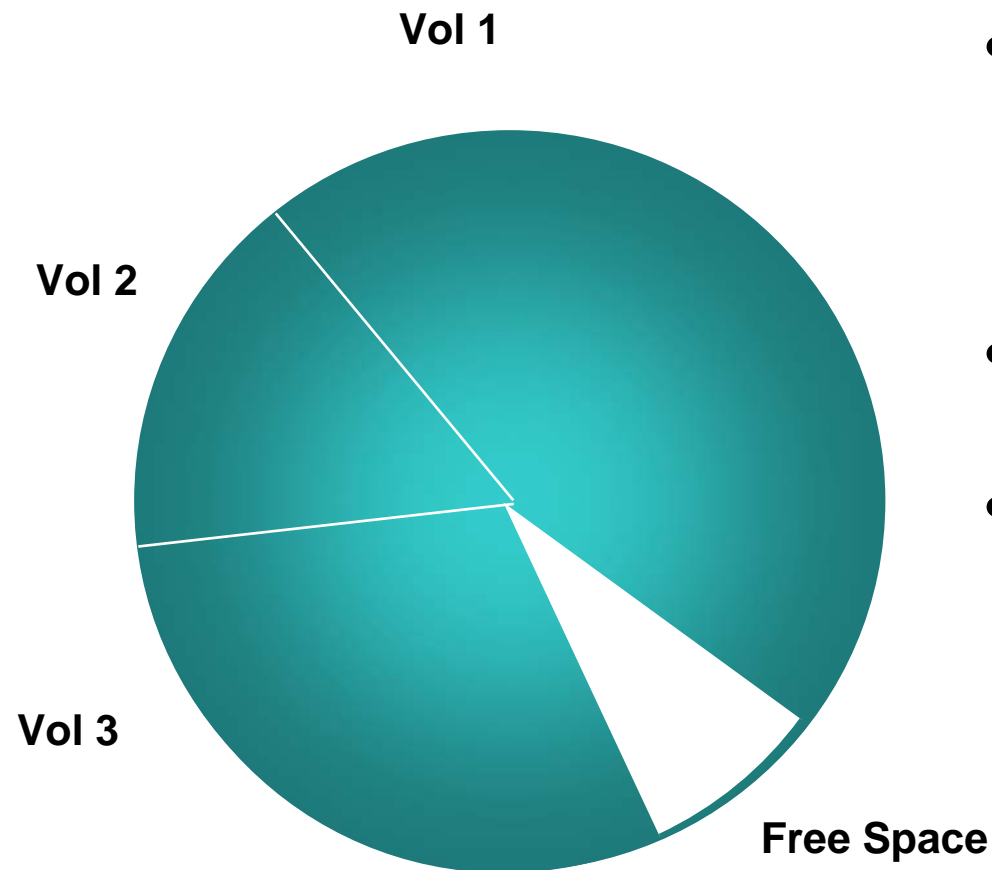

- **Carve up the storage into volumes and leave a little in reserve as a contingency**
- **Volumes can be any size you want them to be**
- **If you get the sizing wrong, you can change it without disruption**

Moving capacity to where it's needed

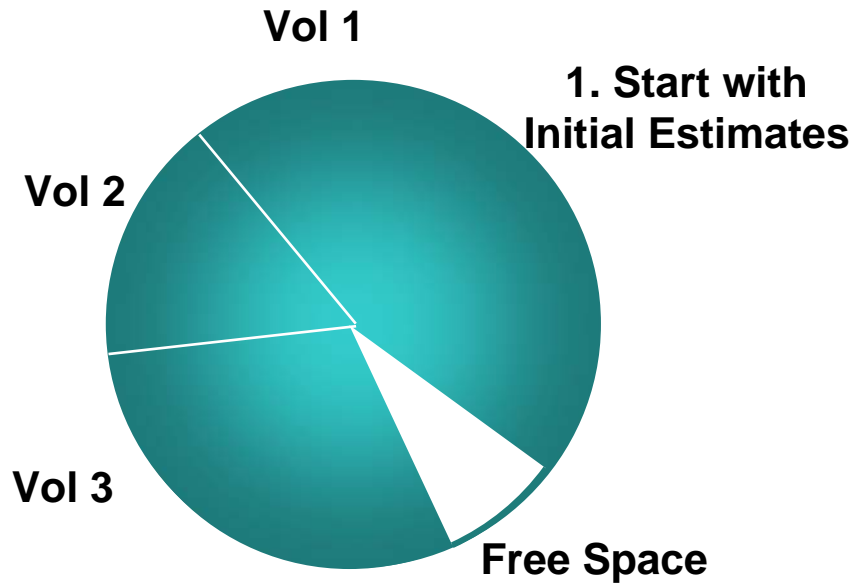

**2. Change your estimates
Based on ongoing data
e.g. Shrink Vol 2**

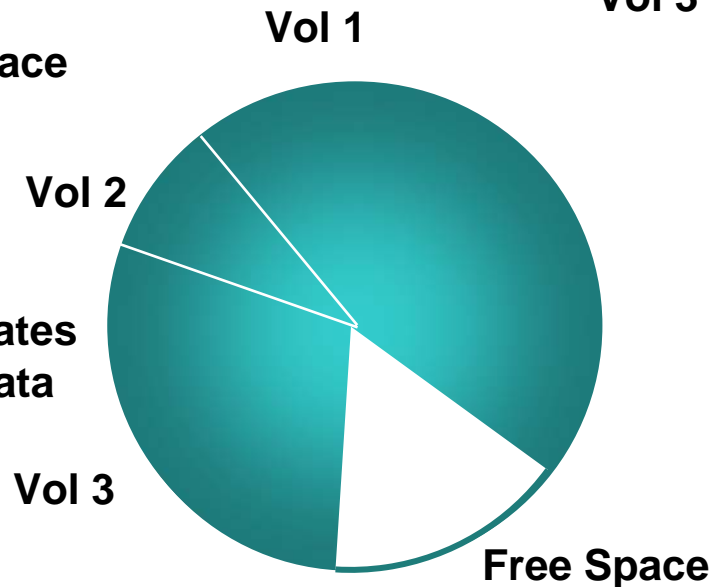

**3. Reallocate Storage
To high growth
Applications
e.g. Enlarge Vol 1**

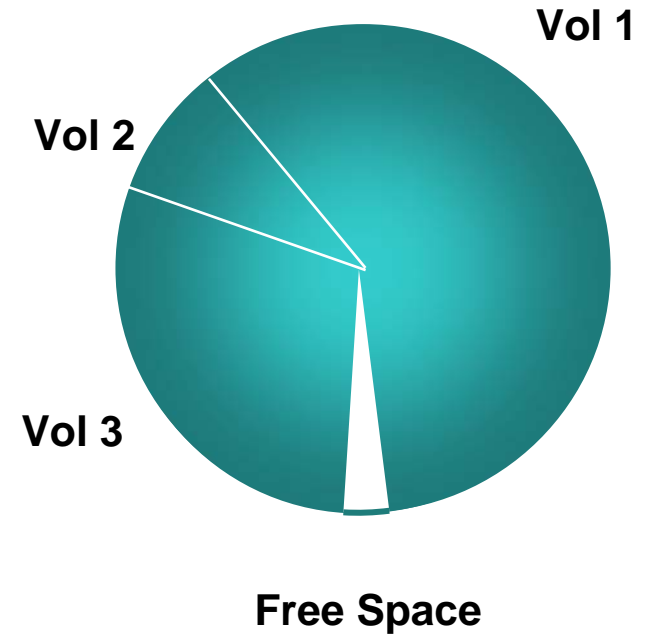

Allocating a Storage “Budget”

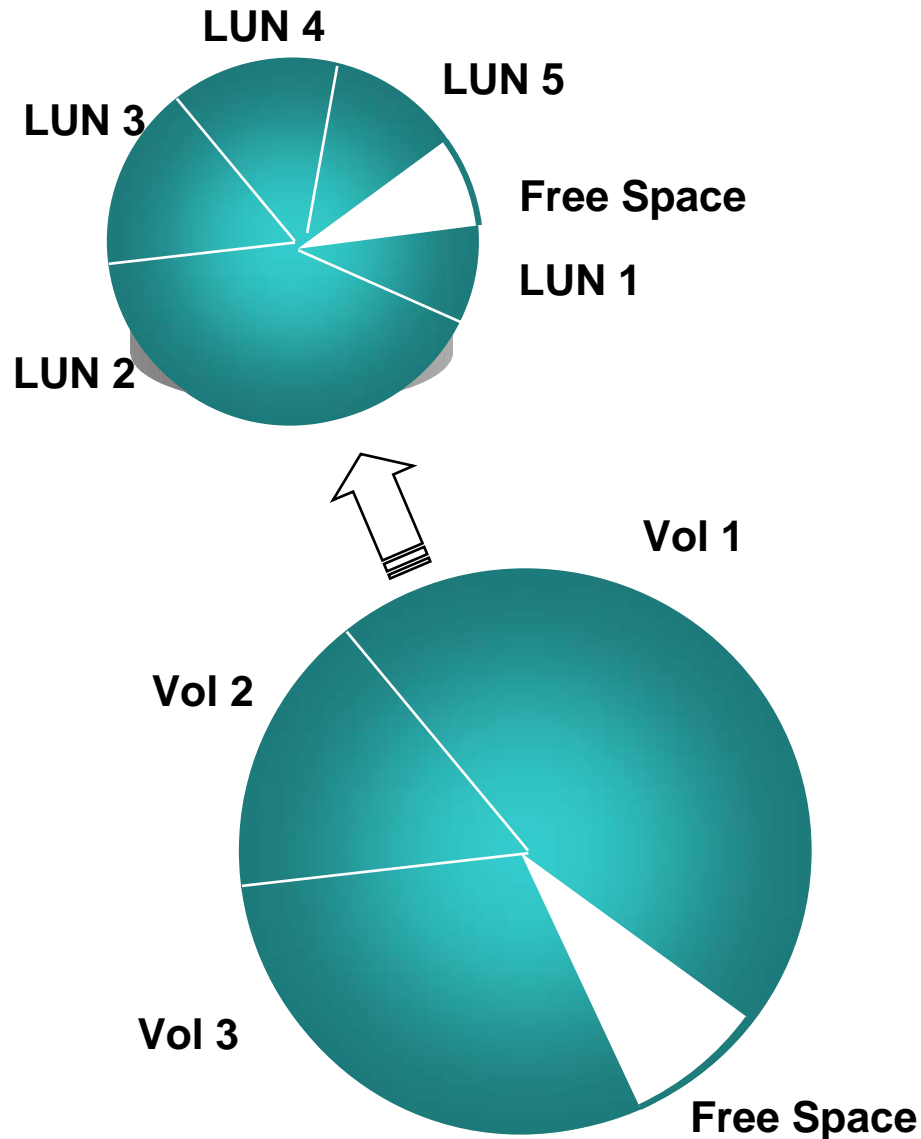

- **Allocate these Volumes to Server Admins who can then easily create and grow their own LUNs**
- **Storage Admins don't have to be involved**
- **If the Server Admin needs more space, they can ask for their Volume size to be increased.**

Go from this...

...to THIS

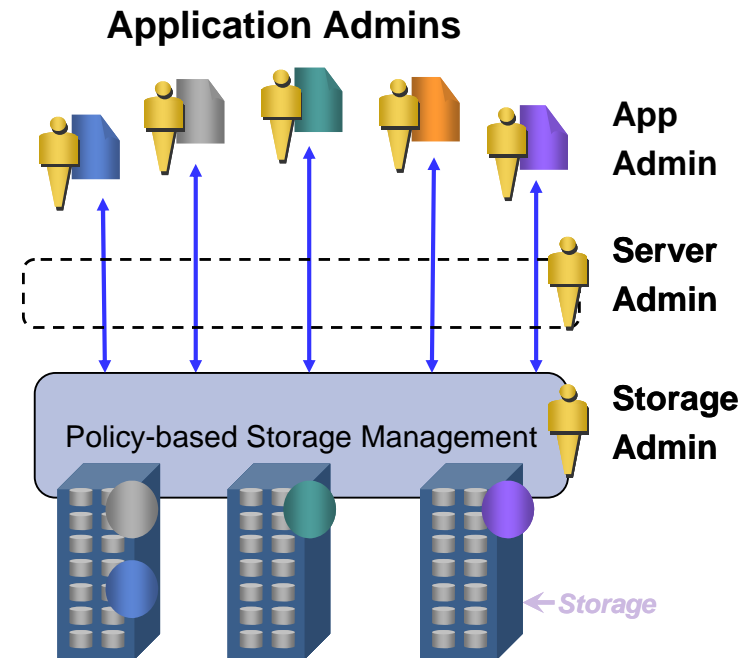
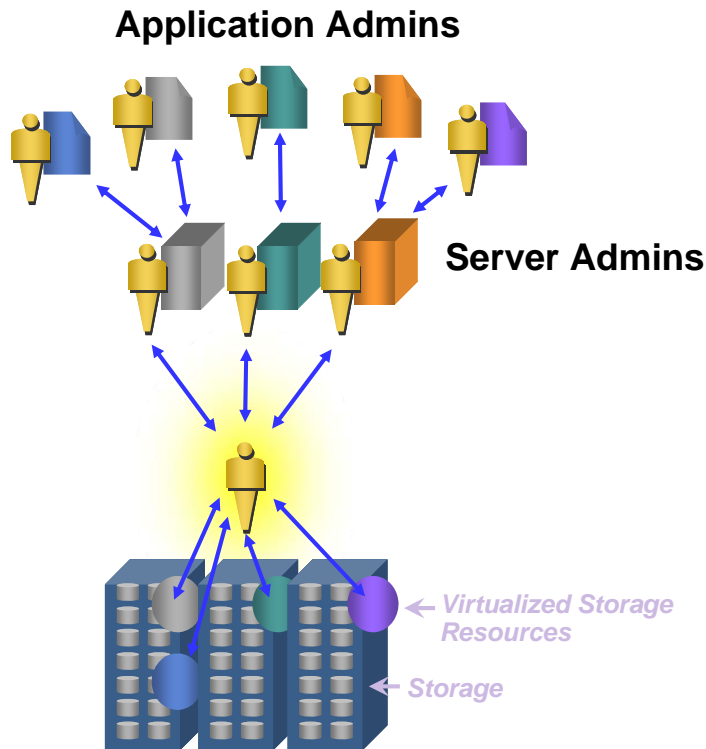

- + administrator productivity
- + storage flexibility
- + efficiency
- + response time

Improve Admin Productivity

Sample Task

Change DB Size

500 DBs X 4 changes per year = 2,000 changes



Storage Industry Model

290 Days

for 1 full time admin

NetApp Model

2 Days

for 1 full time admin

“New project storage activation cycles reduced from eight to 12 weeks to hours.”



Source: Veritest, 5/05. NetApp FAS3020 vs. EMC CLARiiON CX500.



**Oracle Austin Data Center.
Over 20,000 servers.
Over 6,000 TB of NetApp Storage.**

Austin Data Center Stats

- More than 20,000+ servers
 - Largest Dell/Linux installation on earth
- Scaling at over 100 servers/week
- Over 6,400 terabytes of NetApp storage
 - Largest NetApp single installation on earth
- Scaling at over 60TBs of storage each month
- Over 500 mission-critical customers' apps hosted on the premises
- Primary data center for 50,000+ Oracle employees
- 2 acre of data center raised floor space

[Sources: Oracle Magazine Mar/Apr 2005 and Oracle ADC Executives](#)





Making Capacity Management More Efficient

Management Category	Traditional	Flexible Volumes
Changes	Forecast	Dynamically respond
Capacity	Difficult to move	Simple to move
Time	Hours to reconfigure	Minutes to set up
Granularity	Limited and rigid	Precise and flexible
Clones	Time/space intensive	Fast/minimal space

NetApp has unique strength in SAN



- ▶ **If you need to improve your backups and get better utilisation out of your tape infrastructure**
- ▶ **If you need better options for high availability and disaster recovery**
- ▶ **If you need more efficient ways of provisioning your storage**

Put NetApp on your shortlist



Thanks You !